

BGE-1200



ADVANCED FILTRATION TECHNOLOGY

This Aquamor Foodservice brand filter contains a 0.5 micron compressed carbon block. The carbon block provides tremendous capacity to reduce impurities and sediment that may be present in your drinking water. The carbon block has millions of active sites on its surface and within the structure which can absorb impurities like a sponge, and can attract and hold other types of impurities to its surface like a magnet. Additionally, this filter can catalytically breakdown other impurities very similar to the way a catalytic converter works in your automobile. These processes ensure that you are getting the cleanest and best tasting water possible.

This patented Aquamor Foodservice filter requires NO ACTIVATION, is economical and will provide you with months of protection in any beverage or food equipment application.

REPLACES

- Everpure*
2CB5

*Everpure is a registered trademark of Everpure Inc. Northbrook, IL.

BGE-1200

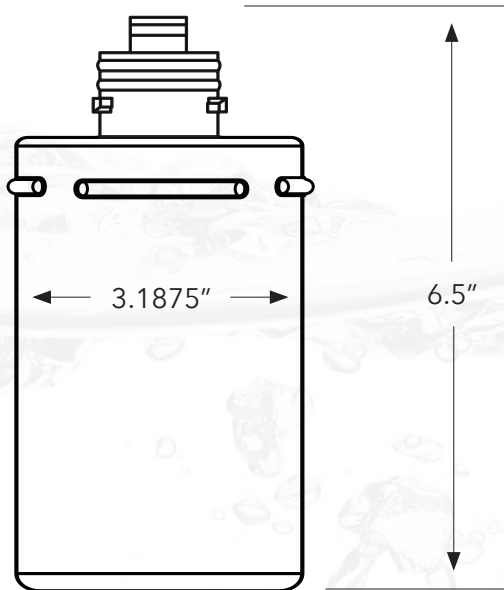

FILTER FEATURES

- No activation required
- Metal housing design
- Three O-ring design provides a water tight seal
- Economical alternative to expensive filter substitutes
- Delivers clean, clear water that looks and tastes great
- Injection molded cartridge liner
- Reduces sand, silt, sediment, rust, chlorine taste and odor from your drinking water
- Designed to provide up to 3,500 gallons of life
- Does not remove minerals which may be beneficial to health
- Patent US D704,554

SPECIFICATIONS

Micron Rating	0.5 Micron
Dimensions	3.1875" x 6.5" (8.1 x 16.51 cm)
Operating Pressure	25-125 psi (1.7-8.6 bar)
Operating Temperature	35°-100° F (1.7°-38° C)
Flow Rate	1.67 gpm (6.32 lpm)
Life	3,500 gallons (13,248 liters)

Do not use with water that is microbiologically unsafe or of unknown quality without adequate disinfection before or after the system.